

# INALT<sup>o</sup>

604.8B05.105



## Features

- 3 speed settings
- 2 LED lights
- 3 aluminium grease filters
- Push button controls
- Stainless steel body

## Performance Features

- 750 m<sup>3</sup>/hr extraction
- Motor type:
  - › Centrifugal
- Decibel rating (dBA) max:
  - › 64-69 dBA

## Cleaning

- Dishwasher safe aluminium grease filters

## Product Dimensions

- Packaged (w, d, h mm)
  - › 950 x 370 x 570mm
- Physical (w, d, h mm)
  - › 900 x 500 x 700-1080mm
- Weight
  - › 28kg

## Accessories

- Expandable 150mm ducting adapter
- Fasteners and wall plugs
- 2 piece stainless steel flue (upper and lower pieces)
- Wall brackets

## Optional Accessories

- Carbon Filter
- Flue extension piece

## Requirements

- Rated voltage:
  - › 220-240V, 50/60 Hz
- Supplied with 10 amp plug

## Warranty

- 24 Months

**Titus**  
Tekform

## Installation

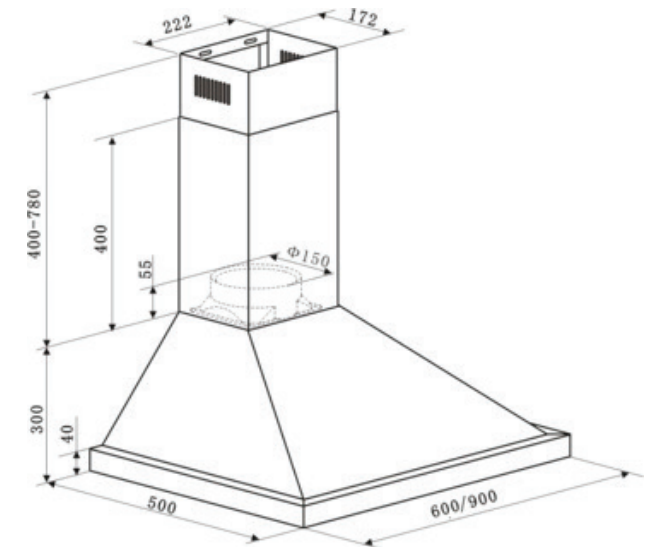

**90cm  
Canopy  
Rangehood**  
/604.8B05.105