

INALT^o

604.8B05.140



Features

- 3 speed settings
- 2 LED lights
- 1 aluminium grease filter
- Push button controls

Performance Features

- 750 m3/hr extraction
- Motor type:
 - > Centrifugal
- Decibel rating (dBA) max:
 - > 64-69 dBA

Cleaning

- Dishwasher safe aluminium grease filter

Product Dimensions

- Packaged (w, d, h mm)
 - > 945 x 340 x 325mm
- Physical (w, d, h mm)
 - > 900 x 296 x 254mm
- Weight
 - > 19kg

Accessories

- Expandable 150mm ducting adapter
- Air outlet adapter
- Pack of screws

Optional Accessories

- Carbon Filter

Requirements

- Rated voltage:
 - > 220-240V, 50/60 Hz
- Supplied with 10 amp plug

Warranty

- 24 Months

Titus
Tekform

Installation

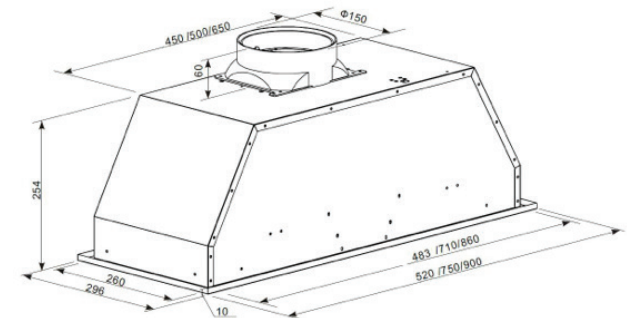

**90cm
Undermount
Rangehood**
/604.8B05.140