

# Technical Data Sheet

## InAlto Appliances from Titus

---



### Titus Construct Appliance Pack 1

DETAILS & ORDERING INFORMATION

<b>Pack Order Number</b>
604.8B05.160



604.8B05.080

#### 600mm Fan Forced Oven

- 600mm fan-forced oven
- 5 functions
- 65ltr capacity
- 120 -minute manual timer
- Cavity cooling system



604.8B05.030

#### 600mm Gas Cooktop

- 600mm
- 4 burner gas cooktop with enamel trivets
- Electronic under-knob ignition
- Metal control knob



604.8B05.125

#### 600mm Slide-out Rangehood

- 600mm twin motor vented or recirculating slide-out rangehood
- 3 speed settings
- 2 incandescent lights
- 2 aluminium grease filters
- Slide controls

INALTO

## DIMENSIONS

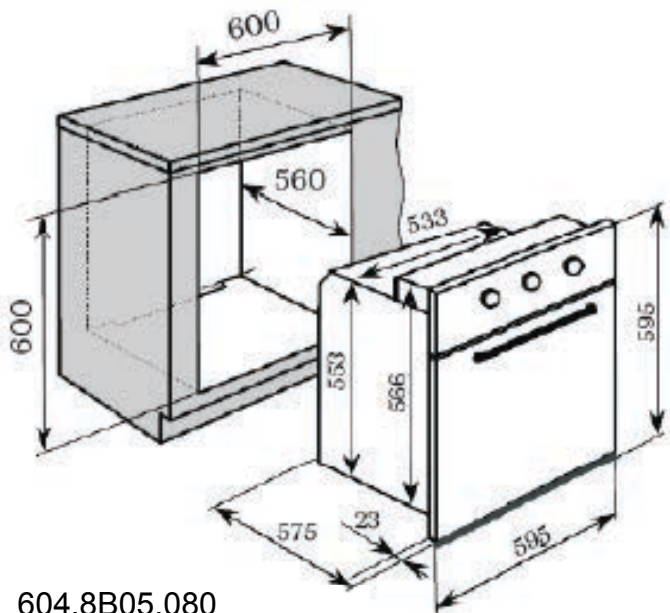

604.8B05.080

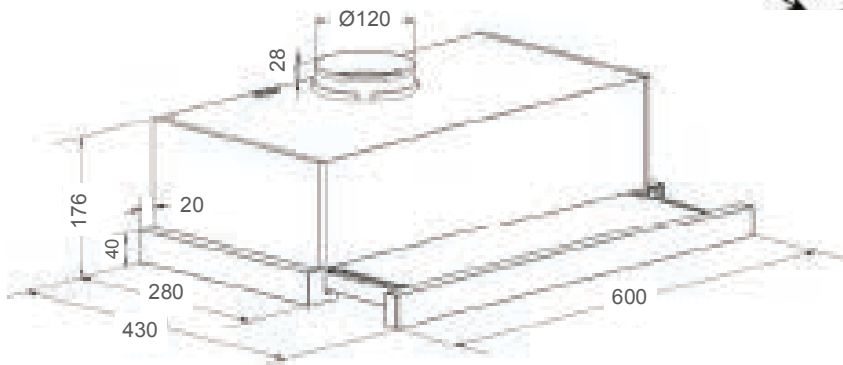
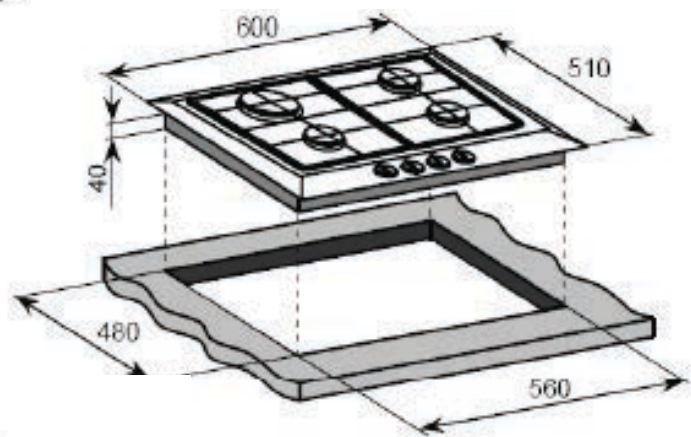

604.8B05.125

## INSTALLATION

Installation guides are supplied with each product order. Please note: All templates, line drawings and electronic files are supplied as a guide only. Please cross check with actual appliance before commencing any installation. Titus Tekform accepts no responsibility for installation errors.

# INALT?