

Technical Data Sheet

InAlto Appliances from Titus

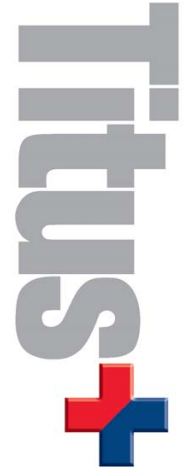

Titus Construct Appliance Pack 2

DETAILS & ORDERING INFORMATION

| |
|--------------------------|
| Pack Order Number |
| 604.8B05.165 |



604.8B05.080

600mm Fan Forced Oven

- 600mm fan-forced oven
- 5 functions
- 65ltr capacity
- 120 -minute manual timer
- Cavity cooling system

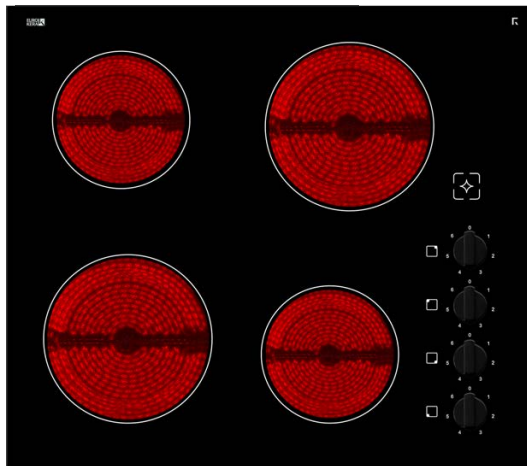

604.8B05.010

600mm Electric Ceramic Cooktop

- 600mm electric ceramic cooktop
- Frameless glass design
- 4 cooking zones with radiant heating elements
- Knob control
- Residual heat indicator lights



604.8B05.125

600mm Slide-out Rangehood

- 600mm twin motor vented or recirculating slide-out rangehood
- 3 speed settings
- 2 incandescent lights
- 2 aluminium grease filters
- Slide controls

INALTO

DIMENSIONS

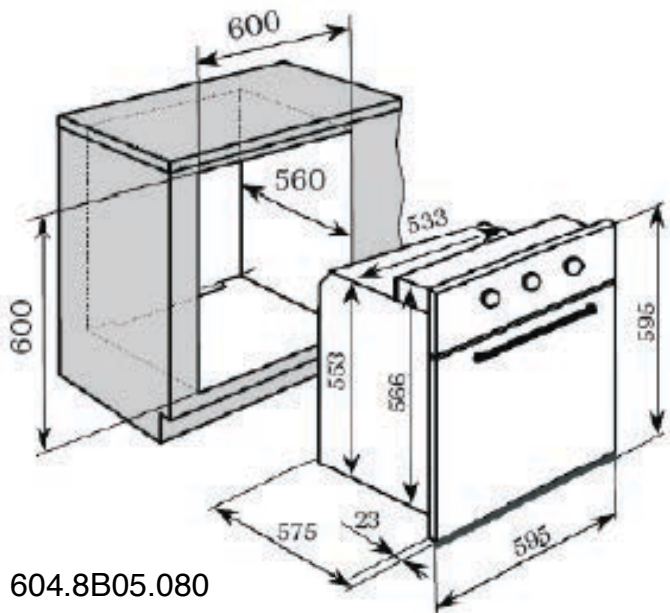

604.8B05.080

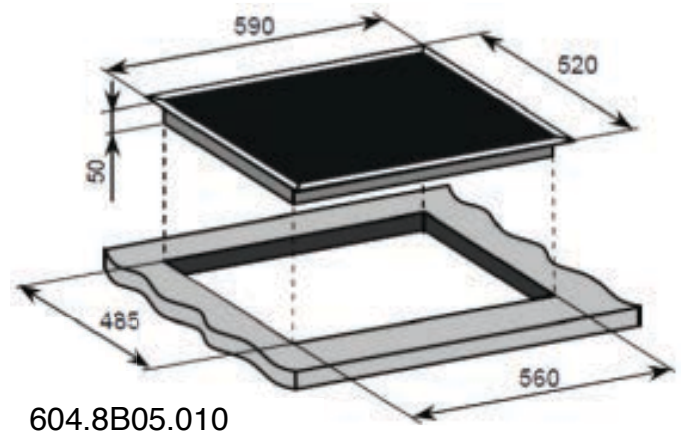

604.8B05.010

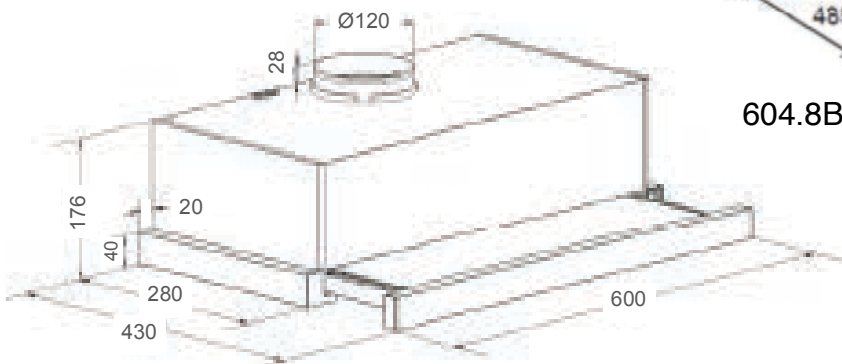

604.8B05.125

INSTALLATION

Installation guides are supplied with each product order. Please note: All templates, line drawings and electronic files are supplied as a guide only. Please cross check with actual appliance before commencing any installation. Titus Tekform accepts no responsibility for installation errors.

INALT?