

**Trade Specials**  
August – October  
2015

# Titus Tekform



**Specials inside**



# ULTRAglaze Made-to-Measure Gloss Doors and Panels

## Setting a High Standard

The ULTRAglaze range is the result of over 20 years of experience by highly trained craftsmen working to exceptionally high standards. Now, our European inspired ULTRAglaze range, takes kitchen and interior design to a new level of sophistication and design.

## Features Include:

- Mirror-like high gloss finish
- Colour fade & UV resistant, surpassing Australian Standards
- Easy cleaning and maintenance
- Technologically advanced sealed product preventing bacteria

## Health and Environment

Unlike painted finished doors and panels, ULTRAglaze utilises E0 (low emissions) MDF-MR board. All components of an ULTRAglaze product are virtually emission and VOC (Volatile Organic Compound) free, especially when compared to traditional painted doors.

ULTRAglaze is the perfect choice for today's environmentally conscious customers, giving them assurance they are safe from exposure to toxic emissions within the home or work place.

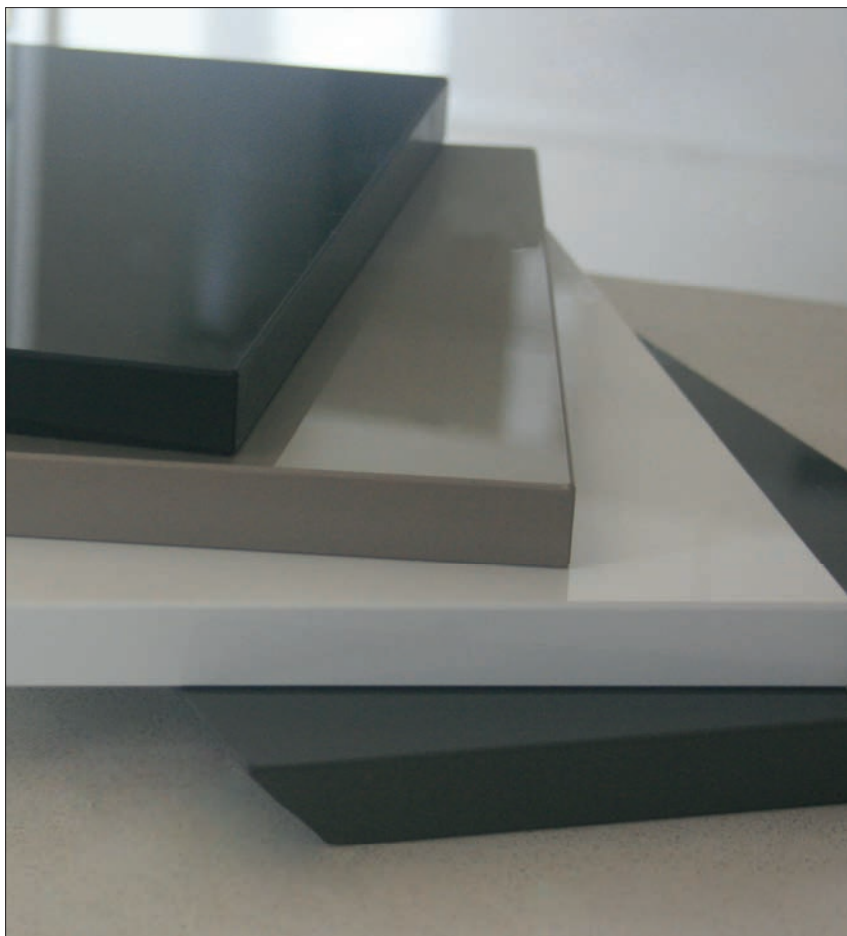

Matching Finish

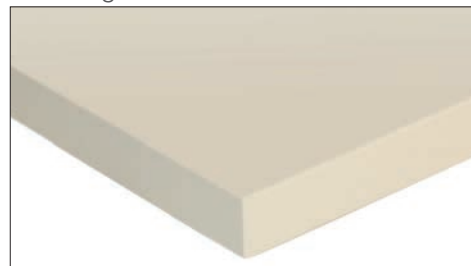

Glass Bead Finish



Aluminium Finish

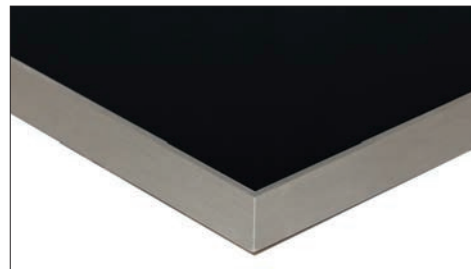

# ULTRAglaZe Made-to-Measure Gloss Doors and Panels

## Colour Options

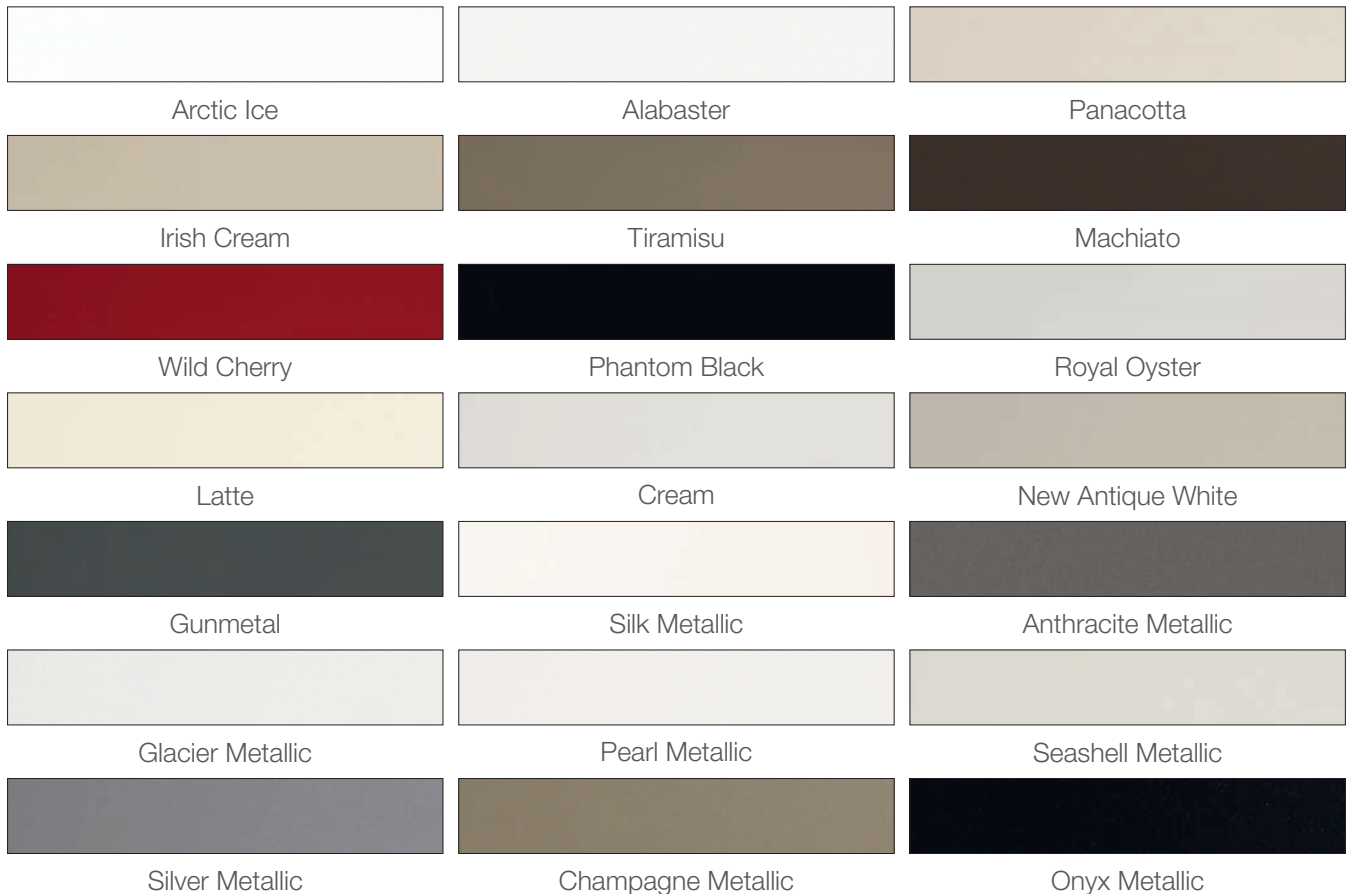

## ShadowLine Features

- Mirror-like high gloss finish
- Superior colour range
- UV resistant surpassing Australian Standards  
Ergonomically designed 40 degree reverse bevel  
EO MR MDF substrate
- Constructed with PUR and laser technology VOC  
(Volatile Organic Compound) free

Order forms are available at  
[www.titustekform.com.au/doors-and-panels](http://www.titustekform.com.au/doors-and-panels)



# Titus Concealed Hinges

- ✓ 60 years manufacturing experience
- ✓ European made – quality fittings
- ✓ Global leaders in fit-for-purpose components

## ST-i2 series

- Damping integrated in the hinge cup
- “Damping switch” allows for tool-less damping force adjustment



## ST series Titus Hinges

- Simple and quick mounting with ST time saving system
- Easy and quick assembly and disassembly
- Built-in Glissando damping system

# Titus Concealed Hinges

Receive a set of ST-i2 hinges and cam adjustable baseplates with every ULTRAgлаze made-to-measure door



## New adjustable base plate for Titus ST-i2 hinges

- FIRA Level H Certified
- Cam adjustability  $\pm 2$  mm
- Built-in adjustment gauge



## ST-i2 Plus 110 hinge

- Easy-fix system
- Integrated damping
- Tool-less damping adjustment
- 11mm cup depth
- Cam depth adjustment

Trade Specials

# ULTRAgglaze Doors and Titus Hinges

**15% off**

of all made-to-measure ULTRAgglaze doors and panels from Titus Tekform during August – October, 2015.



**BONUS!**

For every ULTRAgglaze made-to-measure door ordered during August – October, receive **2 Titus ST-i2 Soft Close hinges with baseplates FREE!**



**2x**

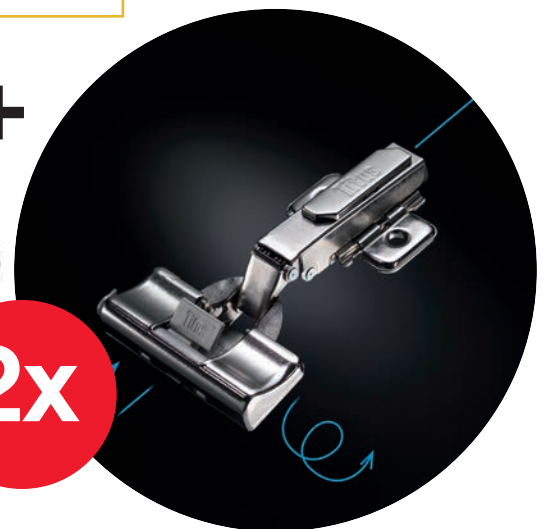

Contact your Titus Tekform Area Manager or email us at [info@titustekform](mailto:info@titustekform) for more information on your next door order

Trade Specials

# How to order your Made-to-Measure ULTRAgglaze Doors

Download document and email, fax or provide copy to your Area Manager

To request a copy of the order forms email us at [info@titustekform.com.au](mailto:info@titustekform.com.au)

**Titus**  
Tekform

**Titus Tekform ULTRAgglaze Door / Panel Order Form**

Please fax, scan & email or post your order forms using the details below

**NSW**  
1 & 2, 41-43 Whyalla Place  
Prestons, NSW 2170  
P:(02) 9826 0007 F:(02) 9826 0074  
E: nsw@titustekform.com.au

**QLD**  
1/02 Northlink Place  
Virginia, QLD 4013  
P:(07) 3266 3999 F:(07) 3266 5234  
E: qld@titustekform.com.au

**VIC**  
Unit 8 / 59 Jersey Road  
Baywater, VIC 3153  
P:(03) 9737 5566 F:(03) 9728 8780  
E: vic@titustekform.com.au

PAGE	OF	Requested delivery date	Contact Name						
		Purchase order No.	SPECIAL NOTES						
Invoice Address		Delivery Address							
State Choose State ▼ Postcode		State Choose State ▼ Postcode							
Telephone		Telephone							
Facsimile		Facsimile							
Alterations and cancellations must be made within 24 hours of the order being placed. Alterations received after this time will incur additional costs.									
<b>Choose Colour:</b> <small>D/S = MATCHING ACRYLIC FRONT AND BACK, S/S = ABS BACKING</small>									
Edge Type (PLEASE CHOOSE) <input type="checkbox"/> 1mm Matching <input type="checkbox"/> 1.3mm Glass Bead <input type="checkbox"/> 1mm Solid Aluminium									
*** All Doors and Panels will be supplied with the ABOVE selected edge.									
*** Mark below in Comments "M" for Edged, "R" for raw or NO edge, "SH" for Shadowline edge									
ITEM	QTY	HEIGHT	WIDTH	L	R	T	B	COMMENTS	D/S
1									Y/N
2									Y/N
3									Y/N
4									Y/N
5									Y/N
6									Y/N
7									Y/N
8									Y/N
9									Y/N
10									Y/N
11									Y/N
12									Y/N
13									Y/N
14									Y/N
FULL SHEETS (2410 x 2410mm) SINGLE SIDED				EDGING (100MTR ROLLS)					
QTY	COLOUR			D/S	QTY	COLOUR			
				Y/N					
				Y/N					
				Y/N					
				Y/N					

\*\*Notes: There is a Grain Direction on Metallic finishes. Doors and panels are 18mm thick. (Some Doubles sided Panels are 18.6mm)



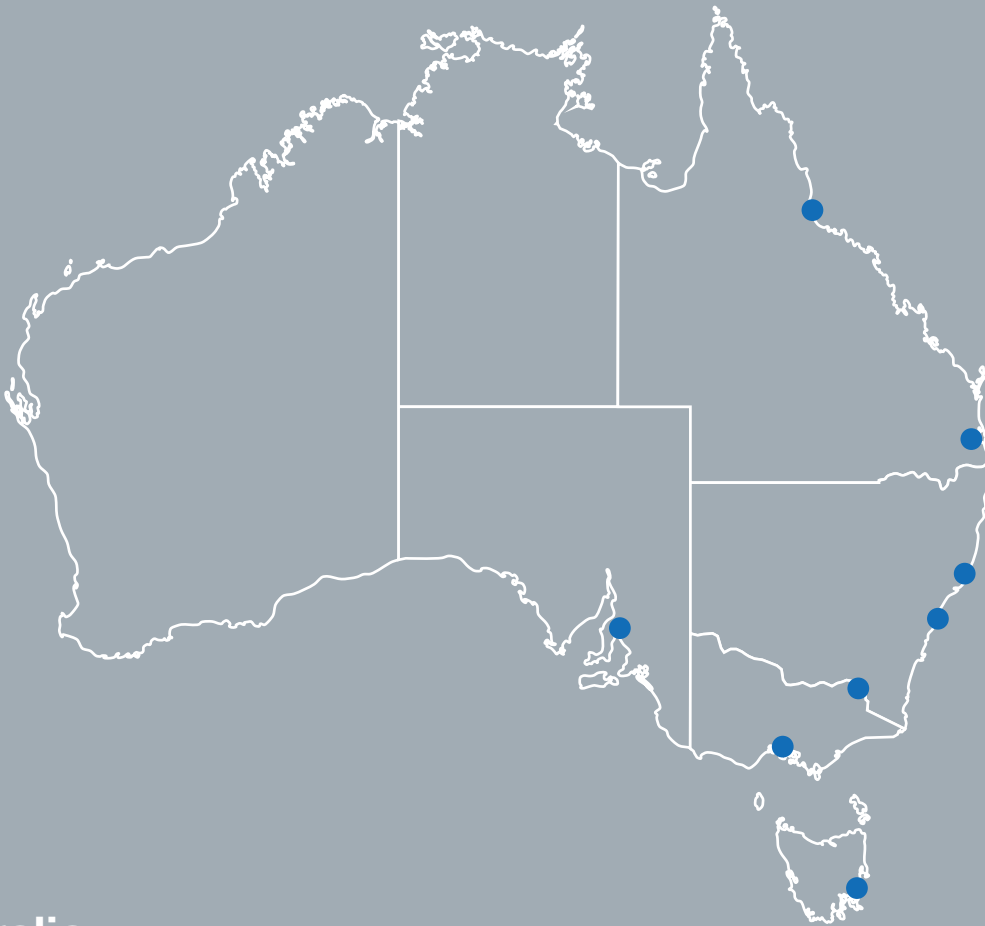

## Australia

### New South Wales

**Titus Tekform Pty Ltd**  
Unit 1&2, 41-43 Whyalla Place  
Prestons, NSW, 2170  
Australia  
T: +61 2 9826 0007  
Fax: +61 2 9826 0074  
ABN: 67 168 439 647

**Titus Tekform Pty Ltd**  
Unit 3, 100 Munibung Road  
Cardiff, NSW, 2285  
Australia  
T: +61 2 4954 4011  
Fax: +61 2 4954 4233

### Queensland

**Titus Tekform Pty Ltd**  
1/32 Northlink Place  
Virginia, QLD, 4014  
Australia  
T: +61 7 3266 3999  
Fax: +61 7 3266 5234  
PO Box 266  
Northgate, QLD, 4013

**Titus Tekform Pty Ltd**  
20 Civil Road  
Garbutt, QLD, 4814  
Australia  
T: +61 7 4779 1366  
Fax: +61 7 4779 1316

### South Australia

**Titus Tekform Pty Ltd**  
PO Box 357  
Bayswater, VIC, 3153  
Australia  
T: +61 8 8447 3700  
Fax: +61 8 8447 3183

### Tasmania

**Titus Tekform Pty Ltd**  
88 Hopkins Street  
Moonah, TAS, 7009  
T: +61 3 6273 1199  
Fax: +61 3 6273 0050  
Australia  
PO Box 658  
Moonah, TAS, 7009

### Victoria

**Titus Tekform Pty Ltd**  
8/59 Jersey Road  
Bayswater, VIC, 3153  
Australia  
T: +61 3 9737 5566  
Fax: +61 3 9729 8780  
PO Box 357  
Bayswater, VIC, 3153

**Titus Tekform Pty Ltd**  
2/20 Mint Street  
Wodonga, VIC, 3690  
Australia  
T: +61 2 6056 3188  
Fax: +61 2 6056 3190

To get in touch with your local Titus Tekform sales representative log onto [www.titustekform.com.au](http://www.titustekform.com.au) or email us at [info@titustekform.com.au](mailto:info@titustekform.com.au)

To find out more about the Titus Group range of products: [www.titusplus.com](http://www.titusplus.com)